

P5-20...R40-17

Model: C18

en

Assembly and Operating Instructions

Tubular drive with integrated radio receiver for ZIP systems

Important information for:

• Fitters / • Electricians / • Users

Please forward accordingly!

These instructions must be kept safe for future reference.

2010 300 901 0b 19/02/2024

Becker-Antriebe GmbH
Friedrich-Ebert-Straße 2-4
35764 Sinn/Germany
info@becker-antriebe.com
www.becker-antriebe.com



BECKER
for you. forever.

Table of contents

General	3
Warranty	3
Safety instructions	4
Instructions for the user	4
Instructions for installation and commissioning	4
Intended use	6
Assembling and disassembling the plug-in connecting cable	6
Assembly	7
First operation	9
Programming the master transmitter	10
Checking that the running direction is correct	10
Intelligent installation management	11
Limit position status indicator	11
Setting the limit positions	11
Lower point to upper point	11
Lower point to upper stop	11
Deleting the limit positions	12
Intermediate positions I + II	12
Programming additional transmitters	13
Deleting transmitters	13
Overwriting the master	14
Setting the limit positions with Auto-install (for ZIP applications with heavy end strip)	14
Obstacle detection (for ZIP applications with heavy end strip)	15
Local operation with a single button	15
Programming the run times	16
Deleting the run times	16
Activating/deactivating the additional fabric untensioning function with the master transmitter	16
Disposal	16
Maintenance	16
Technical data dia. 35	17
Technical data dia. 45	17
What to do if...?	18
Sample wiring diagram	19
Declaration of conformity	20

General

These tubular drives are high-quality products with the following features:

- Optimised for vertical ZIP applications
- Individual, group and central radio control
- No need to run wires to a switch or relay control device
- Any combination of drive and transmitter possible
- Simple to set the limit positions with the transmitter
- Two freely selectable intermediate positions can be set
- Flexible radio grouping; can be altered at any time with no need to install/uninstall
- Integrated memo function facilitates easy programming of one or two switching times on daily repeat.
- Installation without stops possible (from extended point to retracted point)
- Automatic detection of limit positions thanks to intelligent electronic system with stop systems
- The limit positions do not have to be reset: Changes in the shading solution are accommodated automatically when using stop systems.
- Suitable for vertical sun protection
- Considerably reduced stop load, and thus considerably reduced fabric load
- Activate/deactivate the fabric untensioning function
- Left or right hand installation
- Several drives can be operated in parallel
- Automatic adjustment of direction of rotation
- Smooth operation of the system and the drive increases the service life
- For plug-in connecting cable

Please follow these Assembly and Operating Instructions when installing and setting up the device.



The date of manufacture comes from the first four digits of the serial number.

The numbers 1 and 2 indicate the year and the numbers 3 and 4 indicate the calendar week.

Example: 34th calendar week in 2020

Ser. No.:	2034XXXXX
-----------	-----------

Explanation of pictograms

	CAUTION	CAUTION indicates a hazardous situation which, if not avoided, could result in injury.
	ATTENTION	ATTENTION indicates measures that must be taken to avoid damage to property.
		Denotes user tips and other useful information.

Warranty

Structural modifications and incorrect installation which are not in accordance with these and our other instructions can result in serious injuries, e.g., crushing of limbs. Therefore, structural modifications may only be carried out with our prior approval and strictly in accordance with our instructions, particularly the information contained in these Assembly and Operating Instructions. Any further processing of the products which does not comply with their intended use is not permitted.

The end product manufacturer and fitter have to ensure that all the relevant current statutory, official and, in particular, EMC regulations are adhered to during utilisation of our products, especially with regard to end product manufacture, installation and customer advice.

Safety instructions

The following safety instructions and warnings are intended to avert hazards and to prevent property damage and personal injury.

Instructions for the user

General information

- The drive must be disconnected from its power source during cleaning and maintenance and when replacing parts.
- All work, including maintenance and cleaning, on electrical installations as well as other system parts must always be performed by trained technicians, in particular qualified electricians.
- Children from the age of 8 years and persons with reduced physical, sensory or mental capabilities or lack of experience and/or knowledge may use these devices, provided they are supervised or have been instructed in the safe use of the device, and have understood the hazards involved. Children must not play with the device.
- Systems have to be checked regularly by authorised specialists for wear and damage.
- Always put damaged systems out of operation immediately until they are repaired by an authorised specialist.
- Do not operate equipment if people or objects are within the danger zone.
- Observe the danger zone of the equipment during operation.
- Ensure that there is adequate clearance (at least 40 cm) between moving parts and adjacent objects.



Caution

Safety instructions for avoiding serious injuries.

- **Crushing or shearing points must be avoided or protected.**

Instructions for installation and commissioning

General information

- Observe the safety instructions in EN 60335-2-97. Please note that this list of safety instructions is not exhaustive, since it would be impossible for the standard to include all sources of danger. For example, the design of the operated product, the way the drive works in the situation it is installed in or even the way the end product is mounted in the end user's place of use cannot be taken into consideration by the drive manufacturer.
If any questions or uncertainties regarding the safety instructions contained in the standard arise, please contact the manufacturer of the part or end product in question.
- All applicable standards and regulations for electrical installation must be complied with.
- All work, including maintenance and cleaning, on electrical installations as well as other system parts must always be performed by trained technicians, in particular qualified electricians.
- Only use spare parts, tools and accessory devices which have been approved by the drive manufacturer.
Unapproved third-party products or modifications to the system and its accessories represent a risk to your safety and the safety of others. This means that the use of unapproved third-party products, or modifications which have not been agreed with or approved by us, are prohibited. We do not accept liability for damage or injury arising from such actions.
- Position switch with OFF presetting within sight of the driven product, but away from moving parts, at a height of over 1.5 m. This must not be publicly accessible.
- Permanently mounted control devices must be positioned where they can be seen.
- Rated torque and duty cycle must be suitable for the requirements of the driven product.
Technical data - rated torque and service life can be found on the type plate of the tubular drive.
- Hazardous moving parts of the drive must be installed at a height of over 2.5 m above floor level or any other surface from which the drive can be accessed.
- To ensure safe operation of the system after commissioning, the limit positions must be correctly set/programmed in.
- Drives with a H05VV-F connecting cable may only be used indoors.
- Drives with a H05RR-F, S05RN-F or 05RN-F connecting cable may be used both indoors and outdoors.
- To connect the drive to the driven part, solely mechanical accessory components made by the drive manufacturer from the current product catalogue may be used. The components must be installed in accordance with the manufacturer's instructions.

- If the drive is used for shading solutions in a specially marked area (e.g., escape routes, hazard zones, safety areas), compliance with all applicable regulations and standards must be ensured.
- Once the drive has been installed, the fitter must mark the used tubular drive in the “Technical data” chapter and make a note of the installation position.



Caution

Safety instructions for avoiding serious injuries.

- **When electrical or electronic equipment and units are operated, certain components, e.g., the power supply unit, are live. Physical injuries or damage to property can result in the event of unauthorised interventions or failure to heed warnings.**
- **Be careful when touching the tubular drive, as it heats up during operation for technical reasons.**
- **Before installation, shut down all lines and control devices that are not essential for operation.**
- **Crushing or shearing points must be avoided or protected.**
- **When installing the drive, all-pole disconnection from the mains with a contact gap of at least 3 mm per pole must be provided (EN 60335).**
- **If the mains connecting cable is damaged, it may only be replaced by the manufacturer. If the drive has a plug-in connecting cable, it must be replaced with the same type of mains connecting cable, which is available from the drive manufacturer.**

Attention

Safety instructions for avoiding property damage.

- **Ensure that there is adequate clearance between moving parts and adjacent objects.**
- **The drive must not be carried by the mains connecting cable.**
- **All latching connections and fastening screws on the brackets must be checked to ensure that they are secure.**
- **Ensure that nothing rubs against the tubular drive, such as shading solution attachments, screws, etc.**
- **The drive must be fitted horizontally.**

Intended use

The type of tubular drive described in these instructions is intended solely for the operation of vertical ZIP systems.

It may only be used in networked systems if all the individual drives are exactly synchronised and reach the limit positions at the same time.

When mounting connection parts on the drive dia. 35 mm PXX/XX, only use screws EJOT Delta PT 40x12 WN 5454 Torx (9900 000 545 4).

For roller shutter applications, please use only the types of tubular drive designed for this purpose.

This type of tubular drive is designed for use in single systems (one drive per barrel).

The tubular drive must not be used in potentially explosive areas.

The connecting cable is not suitable for transporting the drive. Always carry the drive by the housing tube.

Other applications, uses and modifications are not permitted in order to protect the safety of the users and others, since these actions can impair the system's safety and carry the risk of personal injury and property damage. The drive manufacturer does not accept liability for damages or injury arising from such actions.

Always observe the information in these instructions when operating or repairing the system. The drive manufacturer does not accept liability for damage or injury resulting from improper usage.

Assembling and disassembling the plug-in connecting cable



Caution

The power supply to the connecting cable must be disconnected prior to assembly/disassembly.

Assembling the plug-in connecting cable

Ø35/Ø45/Ø58

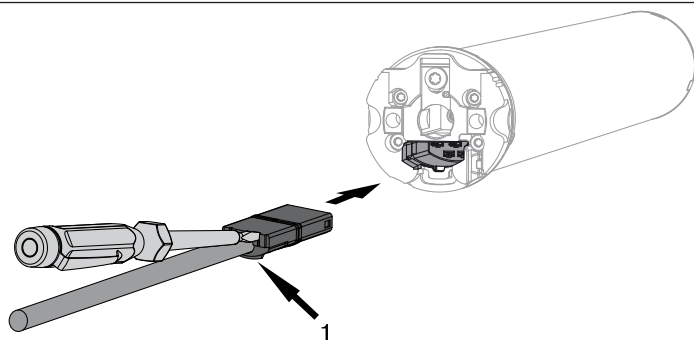

1 = locating lug

Insert the **dead** connecting cable into the drive head until the locating lug clicks into place in the drive. If necessary, use a suitable flathead screwdriver to assist with insertion. Set the screwdriver into one of the two plug grooves provided for this purpose.

Check that the cable is properly engaged.

Disassembling the plug-in connecting cable for tubular drives

Ø35

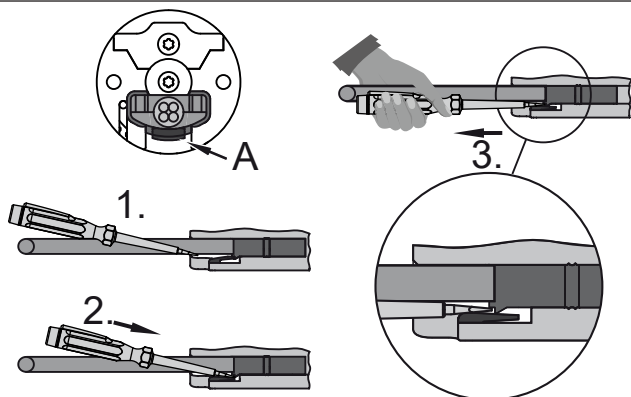

A = snap-in pin

Insert a suitable flathead screwdriver between the locating lug and the snap-in pin, so that the snap-in pin releases the locating lug from the plug.

Now you can pull out the connecting cable along with the flathead screwdriver.

Ø45/Ø58	<p>Insert a suitable flathead screwdriver right into the recess of the locating latch, so that the latch releases the locating lug from the plug.</p> <p>Now you can pull out the connecting cable along with the flat-head screwdriver.</p>
A = locating latch	

Assembly

Assembling the drive

Attention

To connect the drive to the driven part, solely mechanical accessory components made by the drive manufacturer from the current product catalogue may be used.

Prior to mounting, the fitter must ensure that the masonry and the system being motorised are sufficiently robust (drive torque plus weight of the shading solution).



Caution

Electrical connections may only be carried out by a qualified electrician. Prior to assembly, the power supply must be disconnected and secured. Please give the enclosed connection information to the responsible electrical contractor.

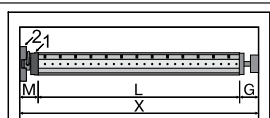

Calculate the space required at the side (M) by measuring the drive head (1) and wall bracket (2). The clear dimension of the box (X) minus the space required at the side (M) and idler (G) gives the length (L) of the barrel: $L = X - M - G$.

The space required at the side (M) varies depending on the combination of drive and wall bracket.

Then mount the wall bracket and idler. Ensure that the barrel is aligned at right angles to the wall and that sufficient axial play is allowed for the mounted system.

Assembling and disassembling the mounting pin

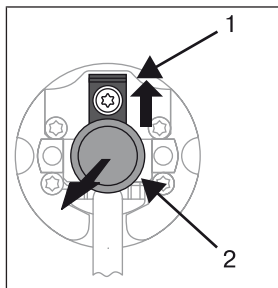

Ø45

When pushed in, the mounting pin (2) locks automatically. To undo the mounting pin (2), push the tab washer (1) upwards and pull out the mounting pin (2).

Assembling and disassembling the drive adapter

Fitting the ring onto the thrust ring

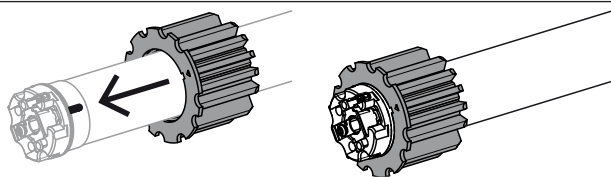

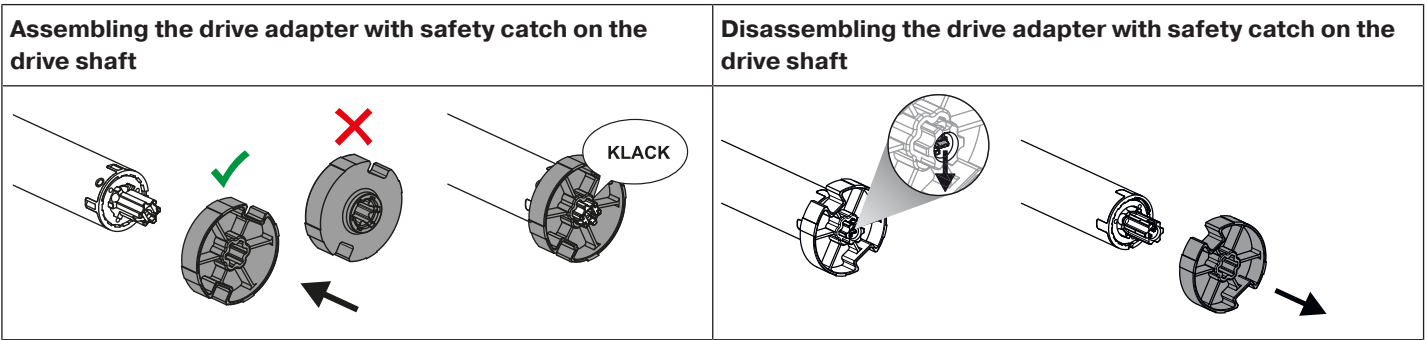

Mounting the drive in the tube

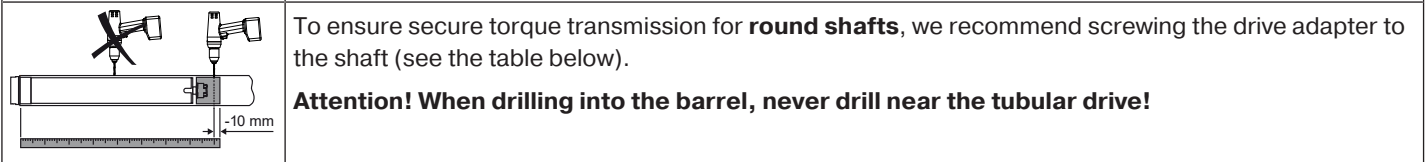
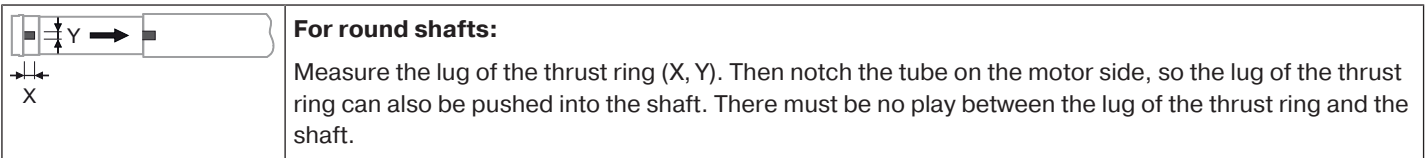
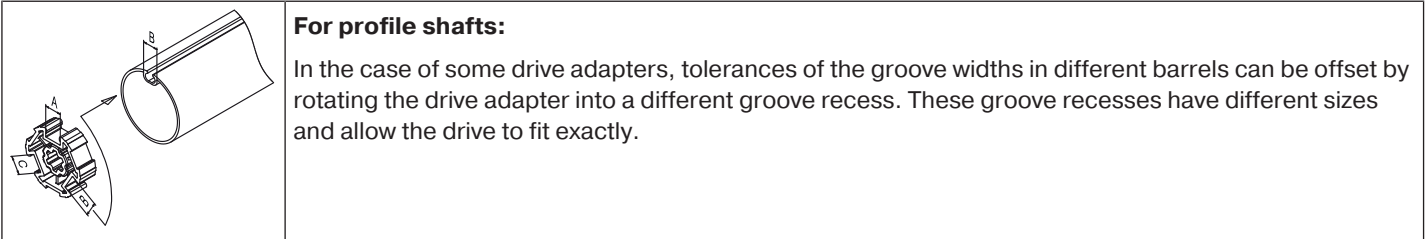

Size of drive [mm]	Drive adapter	Torque max. [Nm]	Fastening screws (4 units)
dia. 35-dia. 45	All	Up to 50	Self-tapping screw dia. 4.8 x 9.5 mm

We also recommend screwing the idler to the barrel.

Attention Do not hammer the tubular drive into the tube or drop it into the barrel!

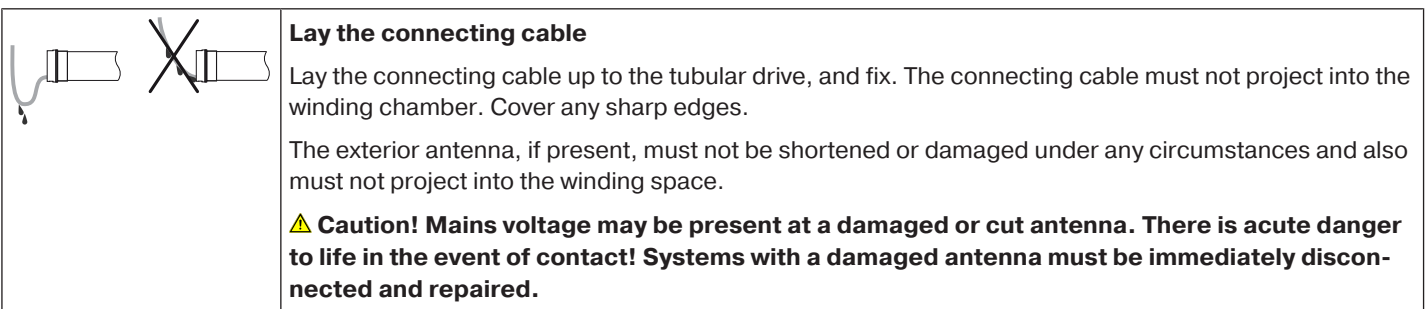
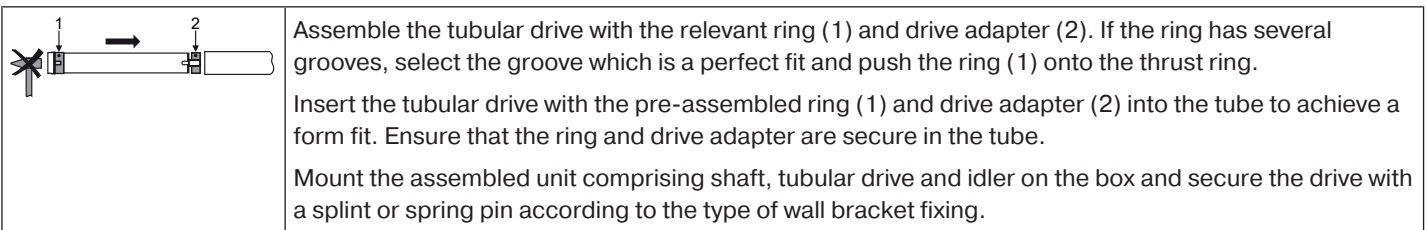

First operation

Explanation of symbols

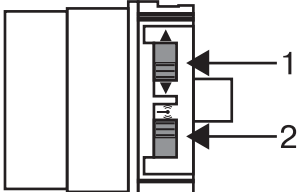
▲	UP button
■	STOP button
▼	DOWN button
●	Programming button (on the transmitter)
(M) ...X	Receiver confirms once or multiple times by "clicking" or "shifting"
	1 = direction switch 2 = radio switch

Attention

The tubular drives are designed for short-time operation. An inbuilt thermal protection switch prevents overheating of the tubular drive. During commissioning (long drop distance or long running time), the thermoswitch may trigger. The drive will switch off. After a short cooling-down period, the system is ready for operation again. The drive does not achieve its full duty cycle until it has cooled to ambient temperature. Avoid a situation where the thermal protection switch cuts in repeatedly.

230V AC / 50 Hz

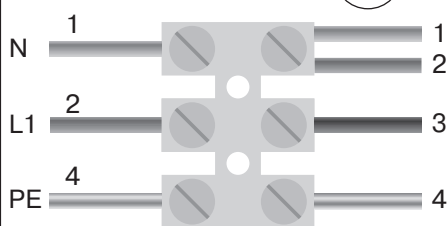

1 = blue

3 = black

2 = brown

4 = green-yellow

Connecting the tubular drive

Connect the tubular drive to the power supply.

Readying the tubular drive for programming

Readying the tubular drive for programming by switching on the power

- ▷ Switch on the power.
- ▶ The tubular drive is ready to programme for 3 minutes



If several tubular drives are to be connected in parallel, you can deactivate the programming mode on one tubular drive by switching the radio switch to the outside position after turning the power on.

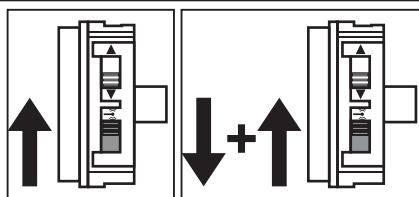

Readying the tubular drive for programming with the radio switch

Switch the radio switch to the inside position. If the radio switch is already in this position, switch it to the outside and back to the inside position.

- ▶ The tubular drive is ready to programme for 3 minutes

Programming the master transmitter

● 3s	Ⓜ 2x	Press the programming button for 3 seconds when it is ready to programme. <ul style="list-style-type: none">▷ The tubular drive acknowledges.▶ The programming process is now complete.
------	------	--

i If a transmitter is already programmed on the receiver, press the programming button for 10 seconds.

Checking that the running direction is correct

i The direction of rotation can only be changed if no limit position has been set.

There are several ways to change the direction of rotation:

- Changing direction of rotation via the direction switch
- Changing direction of rotation via master transmitter

Changing direction of rotation via the direction switch

Press the ▲ or ▼ button.

- ▷ The shading solution runs in the desired direction
- ▶ The running direction is OK.

If the shading solution runs in the wrong direction, the running direction must be changed. Proceed as follows:

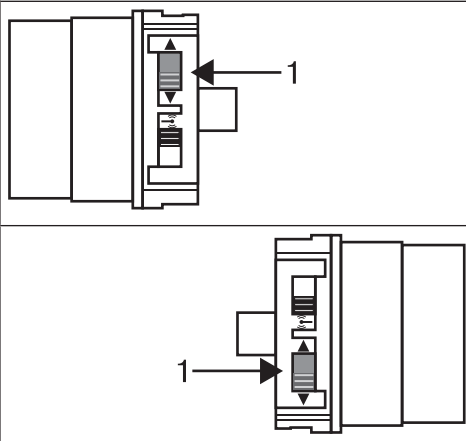

Switch the direction switch (1) to the opposite position.

- ▷ The running direction will now have changed.
- ▶ Check the running direction again.

Changing direction of rotation via master transmitter

Press the ▲ or ▼ button.

- ▷ The shading solution runs in the desired direction.
- ▶ The running direction is OK.

If the shading solution runs in the wrong direction, the running direction must be changed. Proceed as follows:

●+▲+▼ 3s	Ⓜ 3x	First, press the programming button, then within 3 seconds also press the ▲ and ▼ button for 3 seconds. <ul style="list-style-type: none">▶ The tubular drive confirms. Check the running direction again.
-------------	------	--

Intelligent installation management

Completion of installation following automatic setting of limit positions

The drive saves the limit position permanently once the upper limit position is reached 3 times in succession. Installation is then complete. If the limit position is set above a point, this is stored permanently.

Limit position status indicator

A brief stopping and restarting indicates that no limit position has been set in that direction of movement.

Setting the limit positions

i The limit positions can only be set with the master transmitter. The shutter direction must be correct. When setting the limit positions, the tubular drive runs in dead-man mode and limit position status indicator. The lower limit position must always be set first. If the tubular drive switches off prematurely while opening or closing, due to an obstruction, the obstruction can be cleared by opening or closing the screen and removing the obstruction. The desired limit position can be set by opening or closing again.

There are several ways to set the limit positions:

- Lower point to upper point
- Lower point to upper stop
- Auto install (Setting the limit positions with Auto-install (for ZIP applications with heavy end strip) [▶ 14])

The limit position becomes fixed after the tubular drive has turned off **automatically** in the desired position three times.

Lower point to upper point

i There is no shading solution length adjustment with this limit position setting.

▼		Close to the desired lower limit position.
● + ▼	Ⓜ 1x	Press the programming button and, within 3 seconds, also press the ▼ button and hold the two buttons down. ▶ The tubular drive acknowledges.
▲		Then open to the desired upper limit position.
● + ▲	Ⓜ 1x	Press the programming button and, within 3 seconds, also press the ▲ button and hold the two buttons down. ▶ The tubular drive acknowledges. ▶ The limit positions are now set.

Lower point to upper stop

▼		Close to the desired lower limit position.
● + ▼	Ⓜ 1x	Press the programming button and, within 3 seconds, also press the ▼ button and hold the two buttons down. ▶ The tubular drive acknowledges.
▲		Then open as far as the permanent stop. ▶ The tubular drive switches off automatically. ▶ The limit positions are now set.

Deleting the limit positions

Attention

When both or individual limit positions are deleted, all the other set functions (intermediate position I, intermediate position II, obstacle detection, run times) are deleted as well.

i Once set, the limit positions can only be deleted with the master transmitter. Deleted limit positions are displayed on the limit position status indicator.

Deleting individual limit positions

▲ / ▼		Open/close to the limit position to be deleted.
● + ■	(M) 2x	Press the programming button and, within the next 3 seconds, press the STOP button at the same time and hold the two buttons down for 10 seconds. <ul style="list-style-type: none">▷ The tubular drive acknowledges.▶ The limit position is now deleted.

Deleting both limit positions

i Any additional functions that may have been set are deleted at the same time, or are reset to the factory default settings.

▲ / ▼		Open/close the shading solution to a point between the limit positions.
● + ■	(M) 2x	Press the programming button and, within the next 3 seconds, press the STOP button at the same time and hold the two buttons down for 10 seconds. <ul style="list-style-type: none">▷ The tubular drive acknowledges.▶ The limit positions are now deleted.

Intermediate positions I + II

i The intermediate positions I + II are freely selectable positions for the shading solution between the two limit positions. Each travel button can be assigned one intermediate position. Both limit positions must be set before an intermediate position is set.

Setting/modifying the desired intermediate position



▲ / ▼		Open/close the shading solution to the desired intermediate position.
■ + ▲ or ■ + ▼	(M) 1x	Press the STOP button and, within 3 seconds, also press the desired travel button and hold the two buttons down. <ul style="list-style-type: none">▷ The tubular drive confirms.▶ The intermediate position is now saved.

Travelling to the desired intermediate position

2x ▲ or 2x ▼		Press the travel button for the desired intermediate position twice within one second. <ul style="list-style-type: none">▶ The curtain runs to the intermediate position assigned to the travel button.
--------------------	--	---



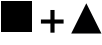
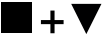



Deleting the desired intermediate position

2x ▲ or 2x ▼		Move the shading solution to the intermediate position that is to be deleted.
--------------------	--	---

 or 	 2x	Now press the STOP button and, within 3 seconds, also press the travel button assigned to the intermediate position and hold the two buttons down. <ul style="list-style-type: none"> ▷ The tubular drive confirms. ▶ The intermediate position is now deleted.
---	---	---

Programming additional transmitters







i In addition to the master transmitter, up to 15 further transmitters can be programmed in the tubular drive.

 3s	 1x	Press the programming button of the master transmitter for 3 seconds. <ul style="list-style-type: none"> ▷ The tubular drive acknowledges.
 3s	 1x	Now press the programming button of a new transmitter which has not yet been programmed in the tubular drive for 3 seconds. Doing so activates the programming mode of the tubular drive for a new transmitter for 3 minutes. <ul style="list-style-type: none"> ▷ The tubular drive acknowledges.
 3s	 2x	Now press the programming button of the new transmitter you wish to program again for 3 seconds. <ul style="list-style-type: none"> ▷ The tubular drive acknowledges. ▶ The new transmitter has now been programmed.







Deleting transmitters

Deleting individual transmitters

i The programmed master transmitter cannot be deleted. It can only be overwritten (see Programming the master transmitter [▶ 10]).

 3s	 1x	Press the programming button on the master transmitter for 3 seconds. <ul style="list-style-type: none"> ▷ The tubular drive acknowledges.
 3s	 1x	Now press the programming button of the transmitter to be deleted for 3 seconds. <ul style="list-style-type: none"> ▷ The tubular drive acknowledges.
 10s	 2x	Then press the programming button of the transmitter to be deleted again for 10 seconds. <ul style="list-style-type: none"> ▷ The tubular drive acknowledges. ▶ The transmitter is now deleted from the tubular drive.

Deleting all transmitters (except the master transmitter)

 3s	 1x	Press the programming button on the master transmitter for 3 seconds. <ul style="list-style-type: none"> ▷ The tubular drive acknowledges.
 3s	 1x	Re-press the programming button on the master transmitter for 3 seconds. <ul style="list-style-type: none"> ▷ The tubular drive acknowledges.
 10s	 2x	Re-press the programming button on the master transmitter for 10 seconds. <ul style="list-style-type: none"> ▷ The tubular drive acknowledges. ▶ All transmitters (except the master transmitter) are now deleted from the receiver.



Overwriting the master

There are two ways to overwrite the master:

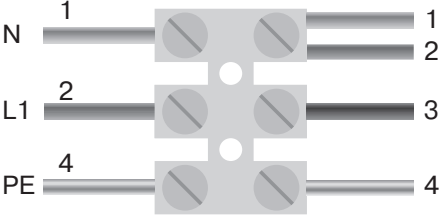

- Readyng the tubular drive for programming by switching on the power
- Readyng the tubular drive for programming with the radio switch

Readyng the tubular drive for programming by switching on the power

i To ensure that the new master transmitter is programmed in the desired tubular drive only, all other tubular drives which are connected to the same power supply must be deactivated from the programming mode. To do so, after switching back on the power, execute a drive or stop command using the transmitter for the given tubular drives or switch the radio switch from inside to outside. If the radio switch is already in this position, switch it to the inside and back to the outside position.

230V AC / 50 Hz			Switch off the tubular drive power for 5 seconds, then switch it back on. ▷ The tubular drive is ready to program for 3 minutes.
			
1 = blue	3 = black		
2 = brown	4 = green/yellow		
● 10s		Now press the programming button of the new master transmitter for 10 seconds. ▷ The tubular drive acknowledges. ▶ The new master transmitter has now been programmed and the old master transmitter overwritten.	

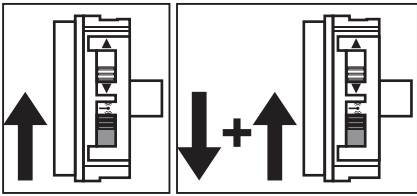
Readyng the tubular drive for programming with the radio switch

			Switch the radio switch to the inside position. If the radio switch is already in this position, switch it to the outside and back to the inside position. ▷ The tubular drive is ready to program for 3 minutes.
● 10s		Now press the programming button of the new master transmitter for 10 seconds. ▷ The tubular drive acknowledges. ▶ The new master transmitter has now been programmed and the old master transmitter overwritten.	

Setting the limit positions with Auto-install (for ZIP applications with heavy end strip)

For proper execution of the auto-install function, the necessary torque in the lower limit position must be at least 1/3 of the rated torque of the tubular drive used.

Example:

Tubular drive 12 Nm, barrel diameter 85 mm ($r = 0.0425$ m, no part of the shading solution is on the barrel when uncoiled). 1/3 of the rated torque equals 4 Nm; this means a minimum weight requirement of approx. 9.6 kg in the lower limit position (shading solution + end strip) for this barrel.

Calculation:

$$4 \text{ Nm} / 0.0425 \text{ m} = 94 \text{ N}$$

$$94 \text{ N} / 9.81 \text{ ms}^2 = 9.6 \text{ kg}$$

i To set the limit positions with Auto-install, you need the "drive adapter for obstacle detection". If electrical power is removed from the drive during downward movement, the process starts again from the beginning with the new downward movement.

▲		Open as far as the permanent upper stop. ▶ The tubular drive switches off automatically.
▼	(M) 1x	Run the fabric downwards until the drive switches off automatically and reverses, while keeping the travel button pressed. The drive now moves one revolution upwards and then down to the lower limit position that has been found, where it switches off. Keep pressing the travel button until the drive confirms once, indicating that the lower limit position that has been found has been saved.
▲		Now move to the upper limit position twice, so that this is also permanently stored.

Obstacle detection (for ZIP applications with heavy end strip)



Caution

Obstacle detection is only active in conjunction with the "drive adapter for obstacle detection".

In addition, please note that the drive must be pushed in to the shaft as far as the band of the thrust ring.

Use of the drive's obstacle detection system as personal protection is not permitted. It has been designed exclusively to protect the sun protection system from being damaged.

If the drive is correctly installed, it switches off when it detects obstructions or fabric faults and tries to run past the obstruction a second time. If this fails, the drive switches off after the third attempt. Approx. 360° from the lower limit position, the drive interrupts operation immediately following the first detection of an obstacle and makes no further attempt to continue.

The total number of attempts to complete a travel that has been started to the respective limit position is limited to 10 (distributed over several obstruction locations).

If reversing is interrupted, a further drive command is only possible in the direction of reversing. Move the fabric without interruption until the tubular drive stops automatically. It is now possible to travel in both directions again.

Local operation with a single button

i Only use a single button (normally open). Only connect one drive for each push-button. The length of cable between the tubular drive and the push-button must not exceed 20 m. The push-button must not be operated during the first five seconds after the mains voltage has been switched on.

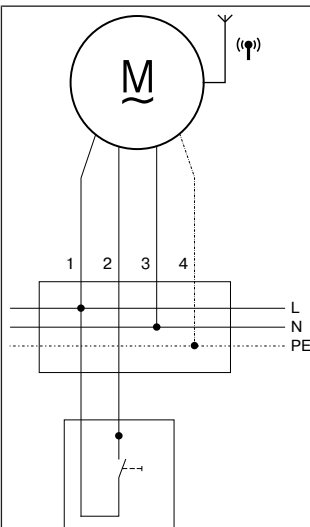

Button (normally open)

Connection

1 = black	2 = brown
3 = blue	4 = green / yellow

Button commands

Operation proceeds in this sequence: "Travel-Stop-Travel-in-the-opposite-direction-Stop".

< 1 second	Moves in maintained operation
> 1 second	Moves in dead-man mode
Double-tap < 1 second	Moves to the intermediate position (in alternation if both are programmed)

Programming the run times

i This function is only available with MemoControl transmitters from the Becker Centronic range of control units.

This tubular drive can save one switching time for one UP and one DOWN cycle.

In the "Timer" slide switch position, the UP and DOWN cycles are automatically repeated every 24 hours.

It does not matter what position the manual/auto slide switch is in when programming the switching time. Stored switching times are overwritten.

1. To program the DOWN run time, the tubular drive must be in the upper limit position, and to program the UP run time it must be in the lower limit position.
2. Wait for the time you wish the automatic drive command to be executed.
3. At the desired time, press and hold the relevant direction button until the tubular drive briefly stops after approx. 6 seconds and then continues to the limit position.
4. Release the direction button.

The tubular drive has saved the current time for this direction of travel.

Deleting the run times

i When deleting, both run times are always deleted.

To delete the UP and DOWN run time, press the STOP button for 10 seconds. The tubular drive makes a "click click" sound to confirm.





The run times are now deleted.

Activating/deactivating the additional fabric untensioning function with the master transmitter

i The "to upper stop" limit position must be set for the fabric untensioning function.

This function is activated on delivery.

Activating/deactivating the fabric untensioning function

		Open the shading solution to the upper limit position.
 3s	 1x	Press the programming button on the master transmitter for approx. 3 seconds. ▷ The tubular drive confirms.
 3s	 1x	Then press the programming button again, and also the STOP and ▼ buttons for approx. 3 seconds. ▶ The tubular drive confirms.

Disposal



The crossed-out bin symbol on the product indicates that the device is subject to mandatory disposal separate from household waste. This product must be handed over to a collection point for electrical and electronic equipment at the end of its service life. The packaging material must be disposed of properly.

Maintenance

These drives are maintenance-free.

Technical data dia. 35

Tubular drive	P5-20	P5-30	P9-16
Model	C18		
Type	CPSOF Z1		
Rated torque [Nm]	5	5	9
Output speed [rpm]	20	30	16
Limit switch range	64 revolutions		
Supply voltage	230 V AC / 50 Hz		
Connected load [W]	115	115	110
Rated current consumption [A]	0.47	0.47	0.47
Operating mode	S2 4 min		
Degree of protection	IP 44		
Min. tube inside diameter [mm]	37		
Frequency	868.3 MHz		
Emission sound pressure level [dB(A)]	≤ 70		

Technical data dia. 45

Tubular drive	R8-17	R12-17	R20-17	R30-17	R40-17
Model	C18				
Type	CPSOF Z1				
Rated torque [Nm]	8	12	20	30	40
Output speed [rpm]	17				
Limit switch range	64 revolutions				
Supply voltage	230 V AC / 50 Hz				
Connected load [W]	100	110	160	205	260
Rated current consumption [A]	0.45	0.50	0.75	0.90	1.15
Operating mode	S2 4 min				
Degree of protection	IP 44				
Min. tube inside diameter [mm]	47				
Frequency	868.3 MHz				
Emission sound pressure level [dB(A)]	≤ 70				

What to do if...?

Problem	Remedy
Tubular drive does not move.	Program new transmitter.
	Bring transmitter within range of the tubular drive.
	Press drive or stop button on transmitter at least five times in the immediate vicinity of the tubular drive.
	Insert battery/batteries correctly in the transmitter or insert new battery/batteries.
	Check electrical connection.
	Thermal protection switch in tubular drive has tripped. Wait until the thermal protection switch in the tubular drive is reactivated.
Running direction on tubular drive cannot be set.	Delete limit positions (see chapter Deleting limit positions) and reset the running direction.
Incorrect running direction after deleting limit positions.	Use the master transmitter or the direction switch on the tubular drive to change the direction of rotation.
Tubular drive overruns the limit position or does not reach the set limit position.	Repair electrical installation and reprogram limit positions.
	Check electrical installation; remove external devices; reset limit positions.
	Stops have broken off or one or several attachments are broken. Repair system; delete limit positions, then reprogram limit positions.
Tubular drive stops arbitrarily; cannot be restarted in the same direction.	Tubular drive is overloaded. Use a higher-torque tubular drive.
	Ensure that the system runs smoothly.
Tubular drive does not run in the right direction.	Tubular drive is overheated. The tubular drive is operational again after a few minutes.
	Tubular drive is faulty (does not run even after standing still for a long period of time). Replace the tubular drive.
	Clear and remove the obstruction and set the drive in the direction required.
	Check the electrical connection.
Tubular drive only runs for approx. 1 second.	Tubular drive is faulty. Replace the tubular drive.
Tubular drive switches off automatically before the first limit position is programmed.	Tubular drive has detected a torque increase. Clear and remove the obstruction. Then move past this position to the desired limit position.
When you attempt to set the limit positions using Auto-install, this does not work.	Use a heavier end strip.
	Close to the desired extended limit position and set a point.
Tubular drive encounters an obstruction and reverses. However, it does not double-check again whether the obstruction is still there.	The installation is not yet complete. Travel to the limit position "Stop" three times.

Sample wiring diagram

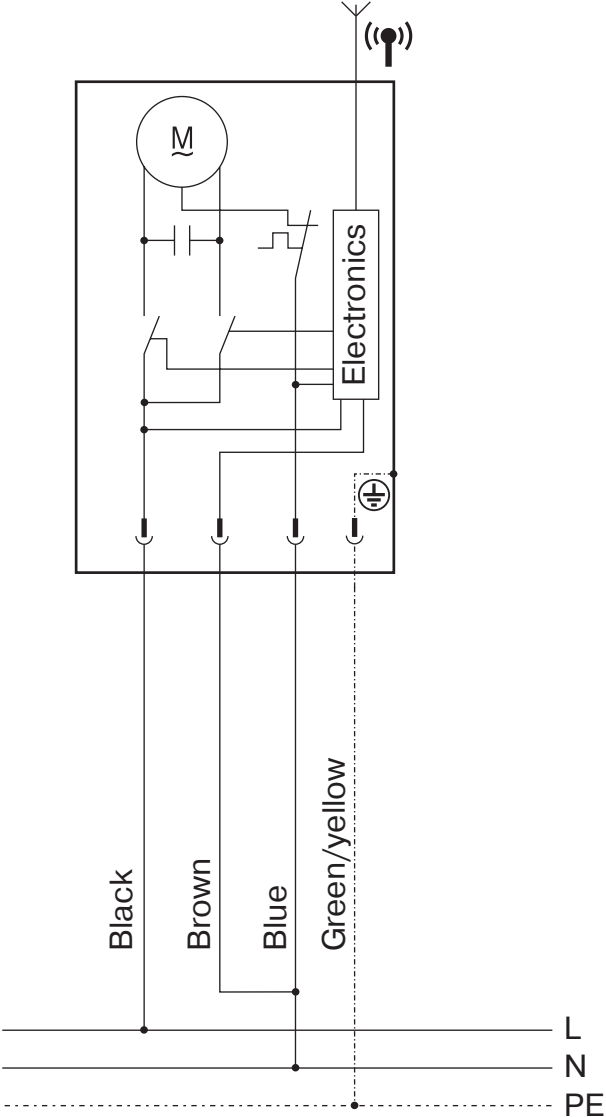

Declaration of conformity

BECKER-ANTRIEBE GMBH
Friedrich-Ebert-Str. 2 – 4
35764 Sinn, Germany



BECKER

- Original -

EU Declaration of Conformity

Document No.: **5100 310 057 0**

We hereby declare that the following product series

Product designation: **Tubular motor**

Type designation: **P3/30.., P4/16.., P5/16.., P5/20.., P5/30.., P9/16.., P13/9..,
R7/85.., R8/17.., R12/17.., R18/11.., R20/17.., R30/11.., R30/17..,
R35/11.., R40/17.., R50/11..,
L44/14.., L50/11.., L50/17.., L60/11.., L60/17.., L70/17.., L80/11..,
L80/17.., L100/11.., L120/11..**

Version: **C, R, S, F, P, E, O, A0...Z9, +**

From serial number: from **233300001**

complies with the applicable regulations of the following Directives:

Directive 2006/42/EC (MD) L157, 09.06.2006

Directive 2014/53/EU (RED) L153, 22.05.2014

Directive 2011/65/EU (RoHS) L174, 01.07.2011

Furthermore, the safety objectives of the **Low Voltage Directive 2014/35/EU** as per Appendix I No.1.5.1 of Directive 2006/42/EC have been met.

Applied standards:

DIN EN 60335-1:2020

DIN EN 60335-2-97:2017

DIN EN 61000-6-3:2022

EN 301489-3:2019

EN 14202:2004

Authorised party for the compilation of the technical documentation:
Becker-Antriebe GmbH, Friedrich-Ebert-Str. 2 – 4, 35764 Sinn, Germany

This declaration of conformity was issued:

Sinn, 08.08.2023

Place, Date

Maik Wiegemann, Management

This declaration certifies compliance with the Directives cited but does not represent any assurance of characteristics. The safety warnings in the supplied product documentation must be observed!

CE Antriebe C_ 5100 310 057 0- _en

Initial setup - tubular drive - Type C18

Setup with master transmitter

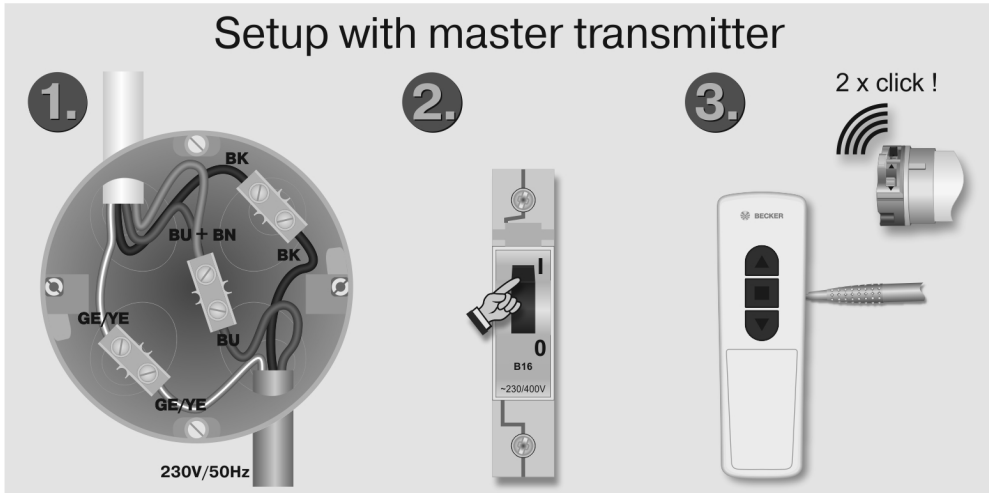

Change of rotational direction

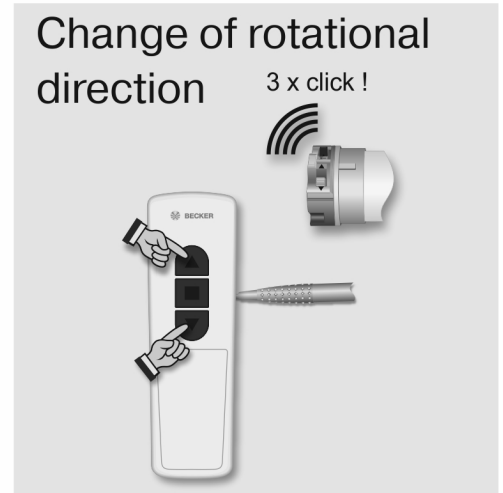

Auto-Install

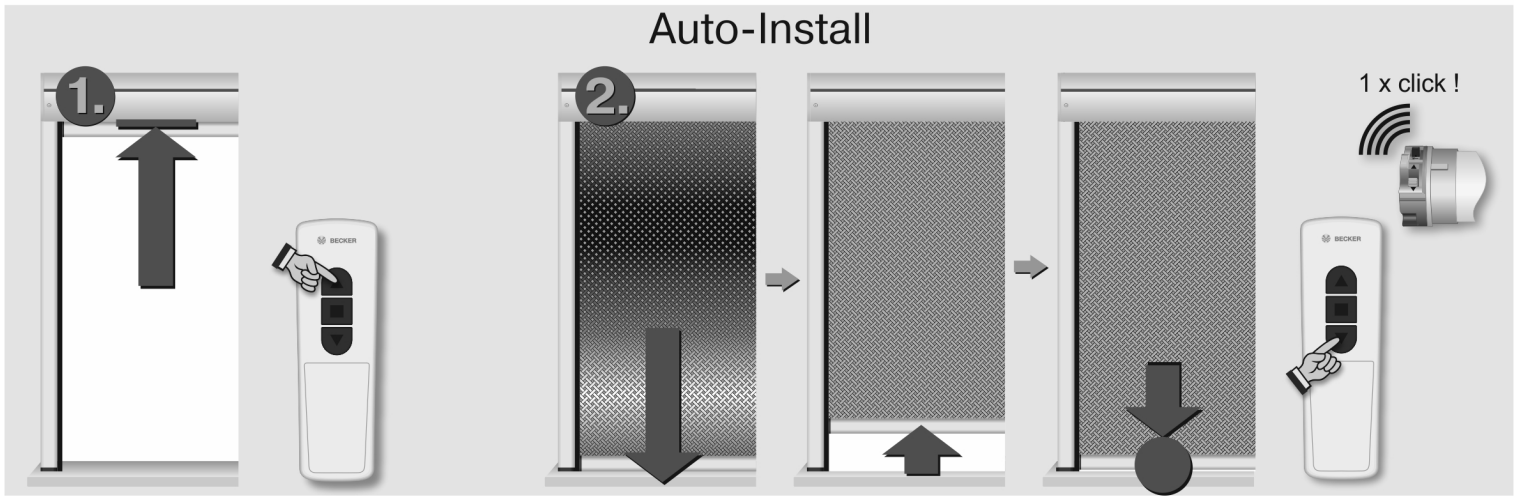

Programming End Limit Position

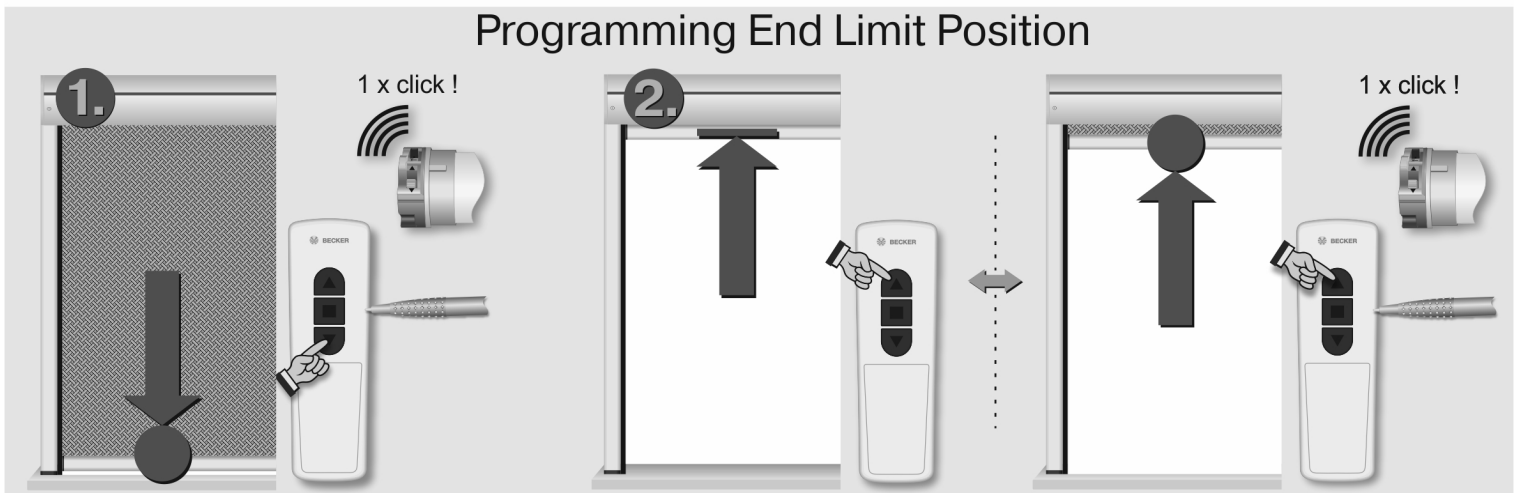

Deleting End Limit Position



Activate/deactivate the fabric utensioning function

